

- Power Regulation
- Fans
- Thermistors
- Endstops
- USB

- H10 MountingHole
- H11 MountingHole
- H12 MountingHole
- H13 MountingHole

- Heater_2
- Heater_1

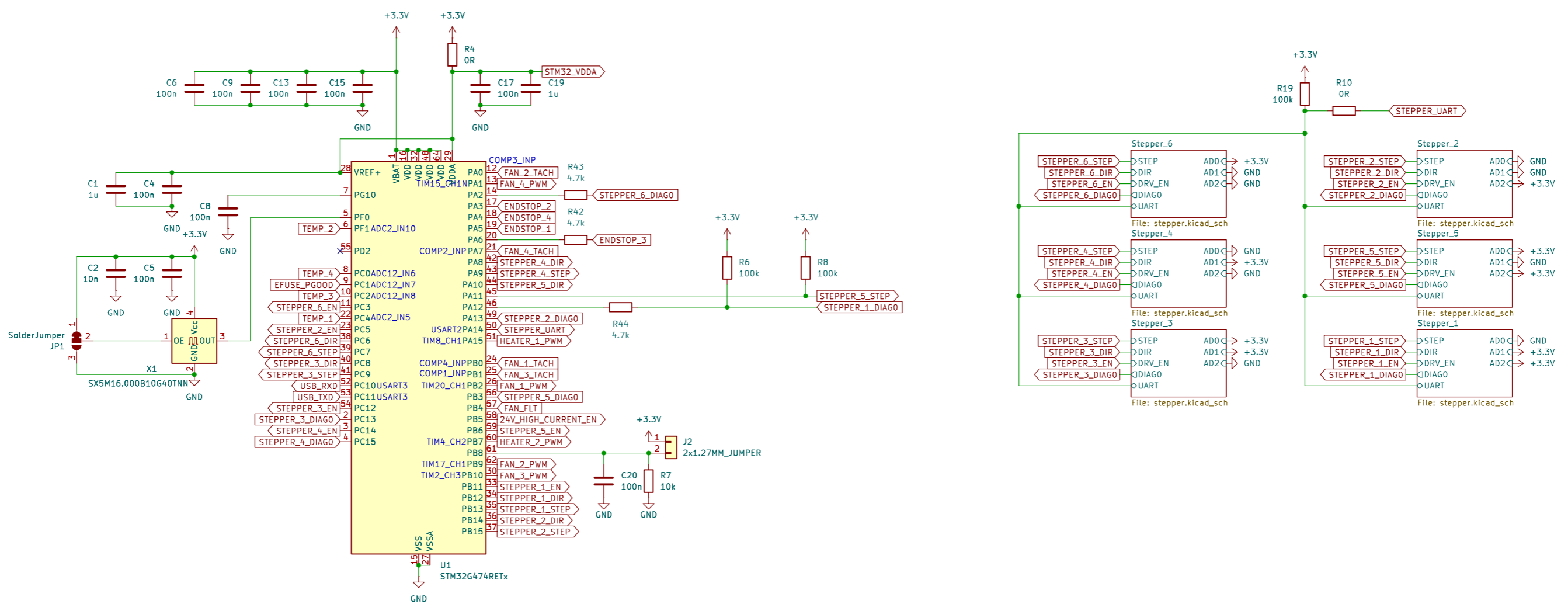
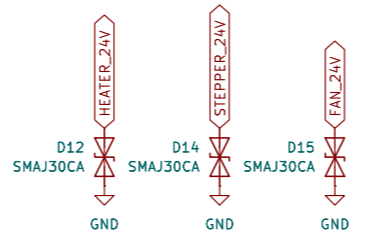

Sheet: /		
File: prunt_board_2.kicad_sch		
Title:		
Size: A3	Date:	Rev:
KiCad E.D.A. 8.0.6		Id: 1/14

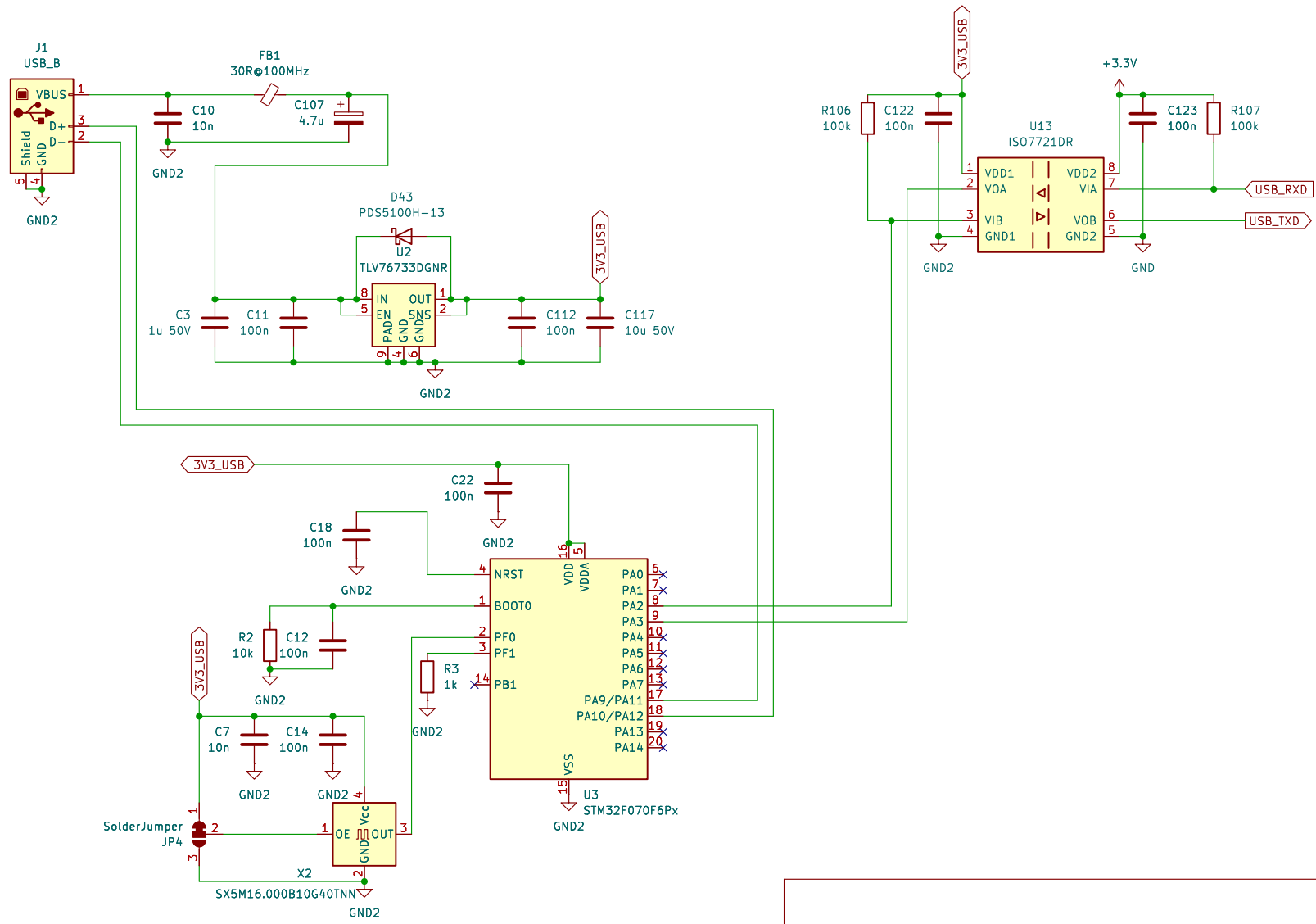

Sheet: /USB/		File: usb.kicad_sch	
Title:			
Size: A4	Date:	Rev:	
KiCad E.D.A. 8.0.6		Id: 2/14	

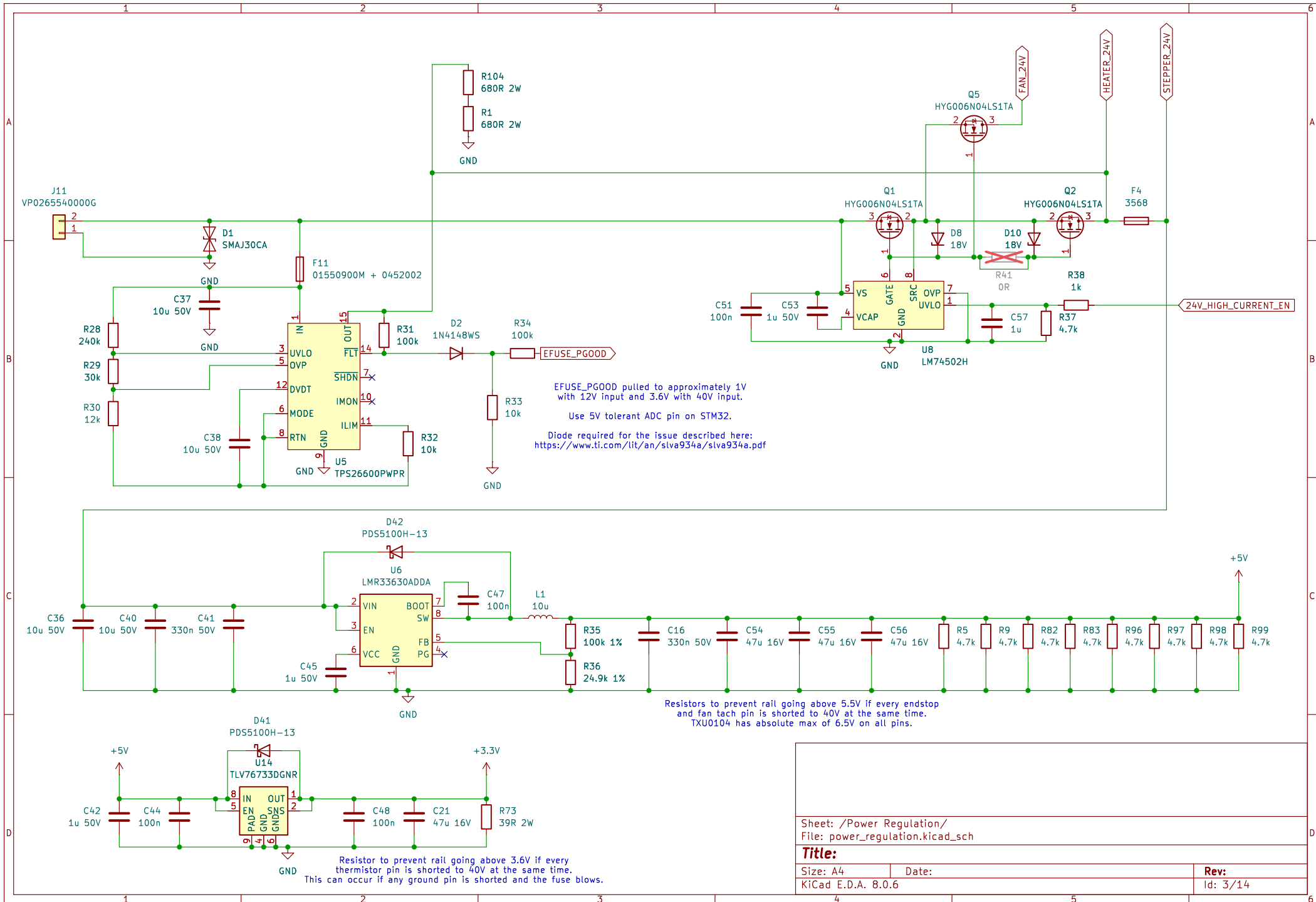

Sheet: /Power Regulation/
 File: power_regulation.kicad_sch

Title:	
Size: A4	Date:
KiCad E.D.A. 8.0.6	Rev:
	Id: 3/14

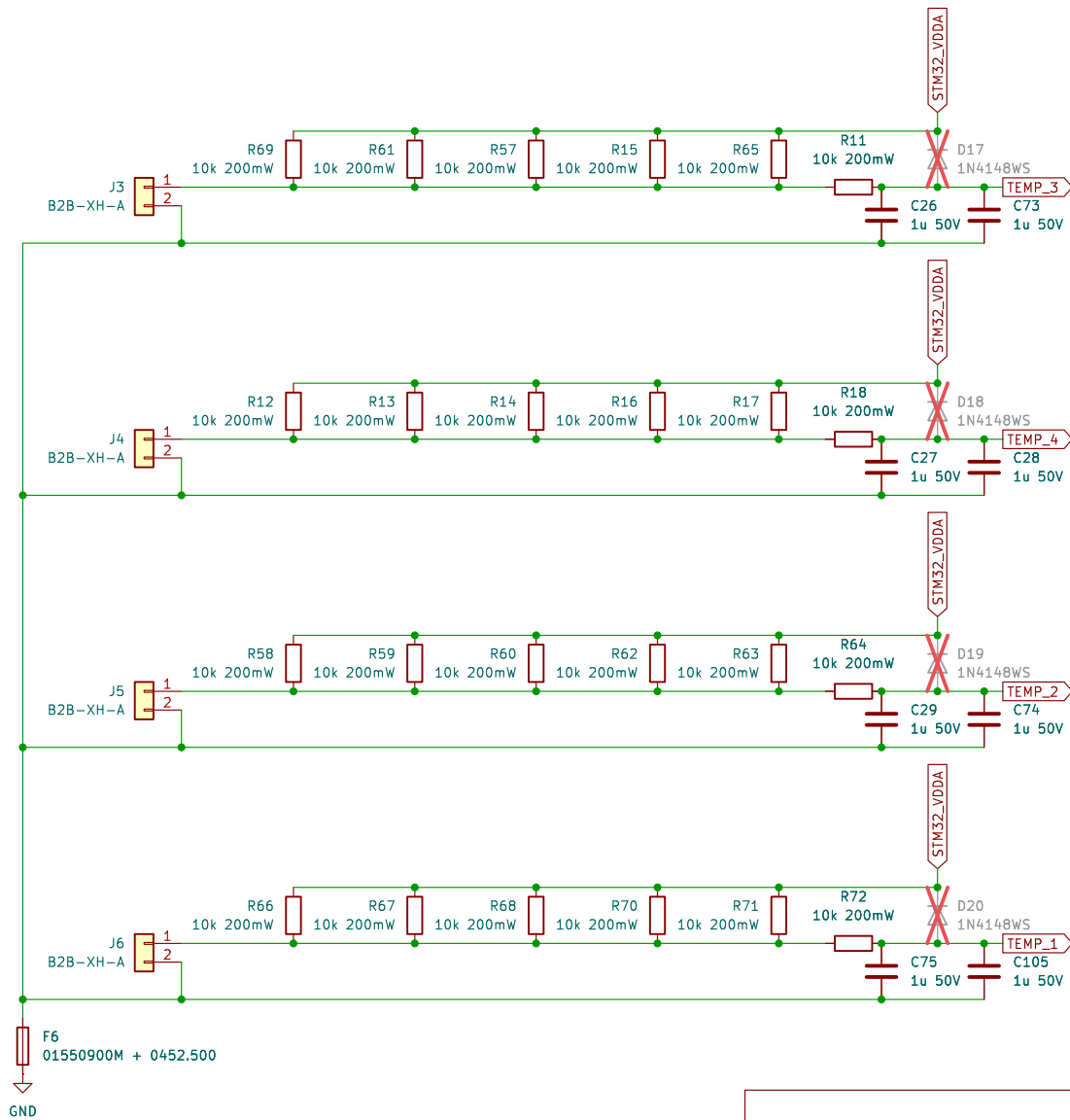

Diodes removed due to large leakage current at high temperatures.

Sheet: /Thermistors/	
File: thermistors.kicad_sch	
Title:	
Size: A4	Date:
KiCad E.D.A. 8.0.6	Rev: 4/14

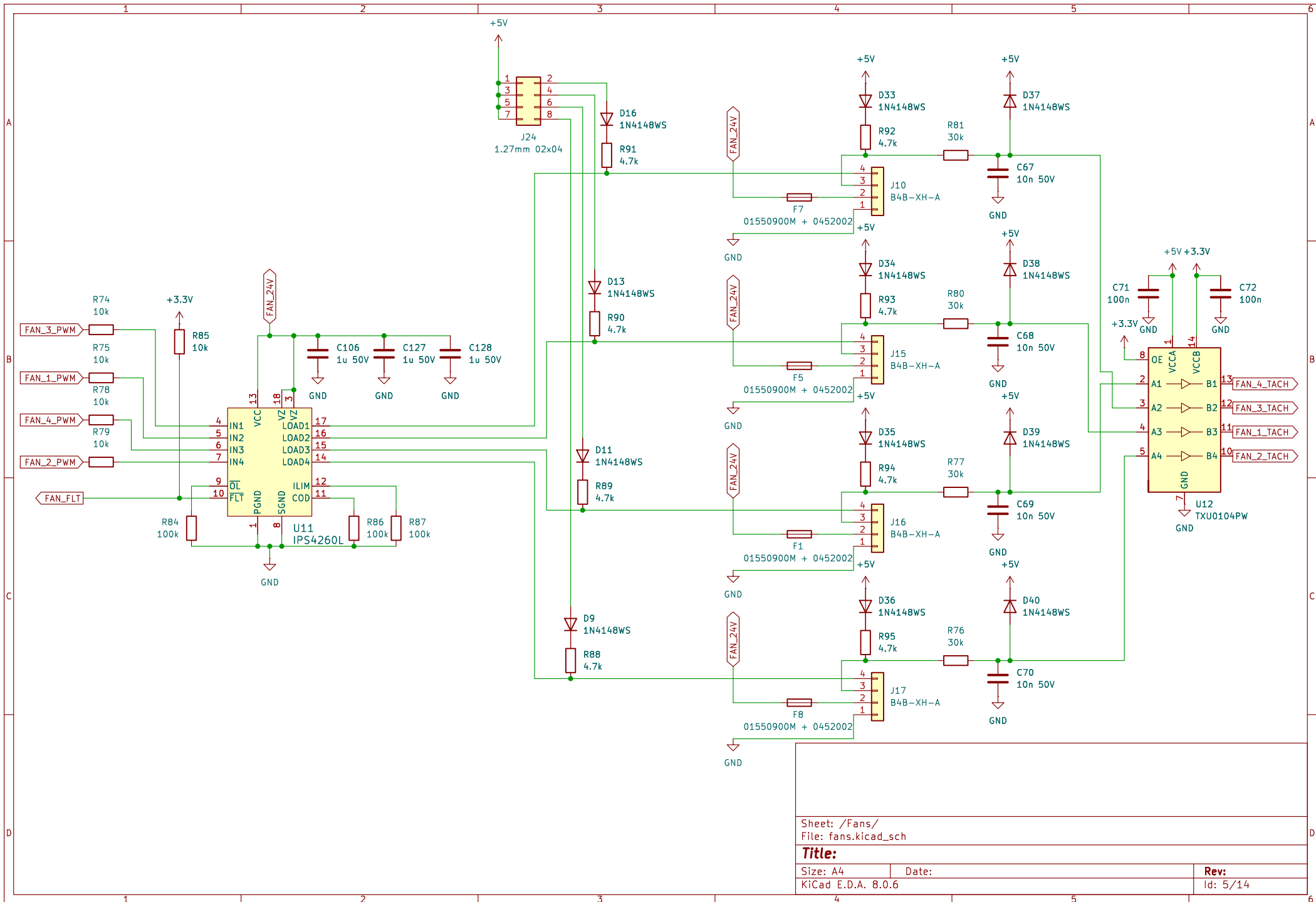

Sheet: /Fans/
 File: fans.kicad_sch

Title:

Size: A4	Date:
KiCad E.D.A. 8.0.6	Rev: Id: 5/14

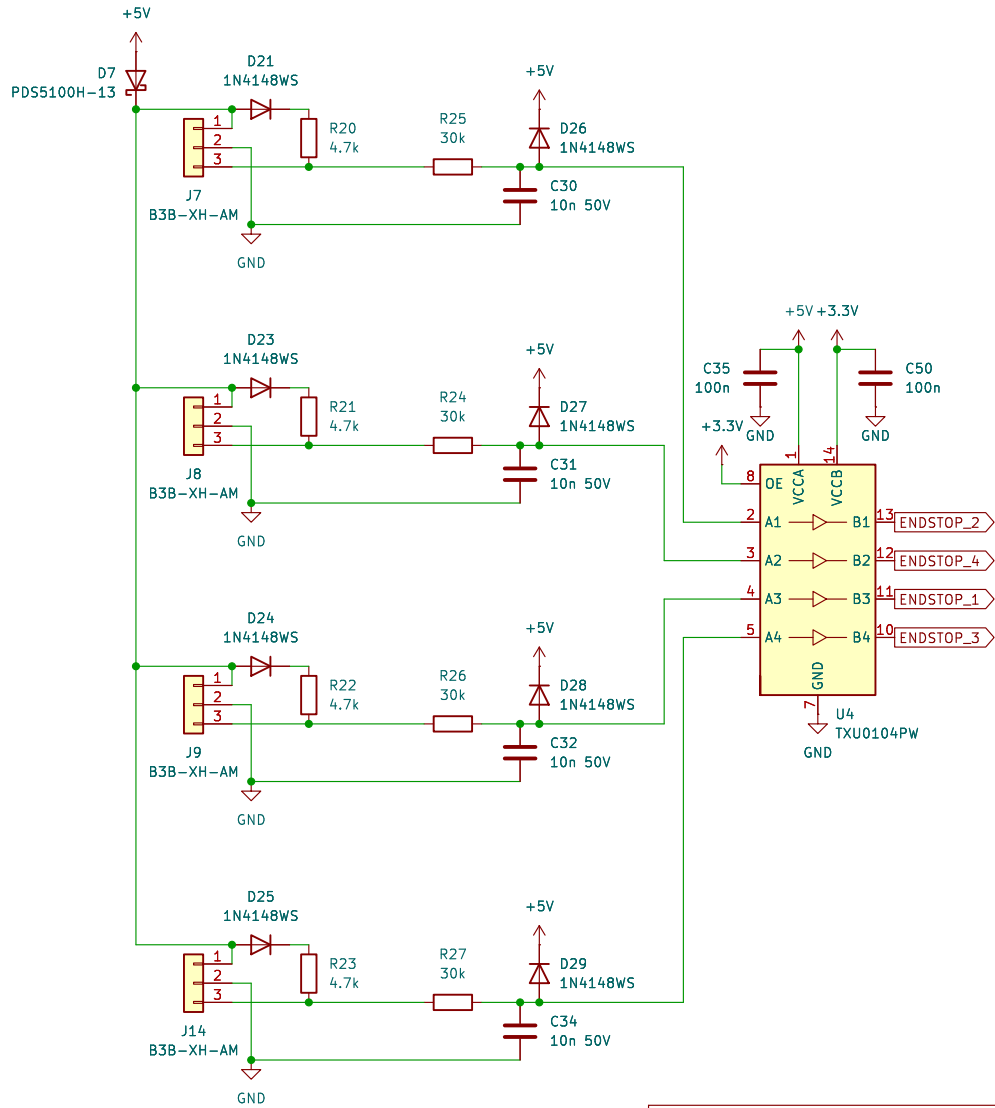

Sheet: /Endstops/
 File: endstops.kicad_sch

Title:

Size: A4
 KiCad E.D.A. 8.0.6

Date:

Rev:
 Id: 6/14

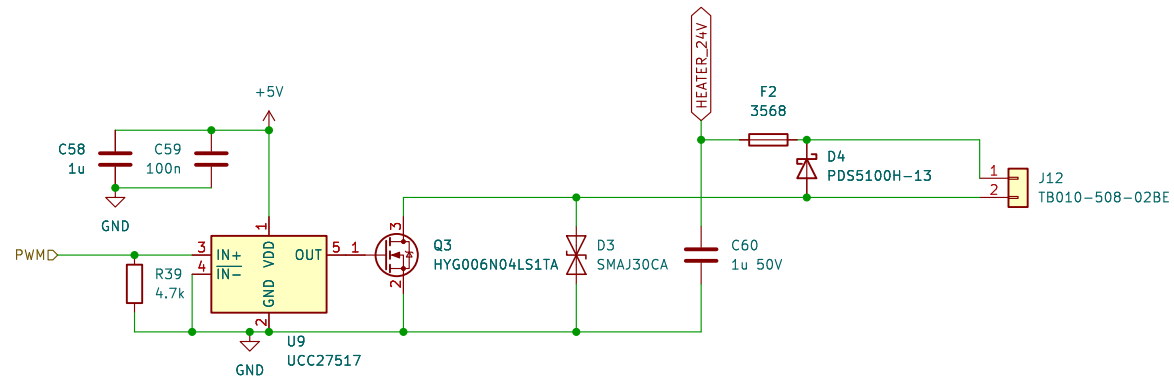

Sheet: /Heater_1/
 File: heater.kicad_sch

Title:

Size: A4
 KiCad E.D.A. 8.0.6

Date:

Rev:

Id: 7/14

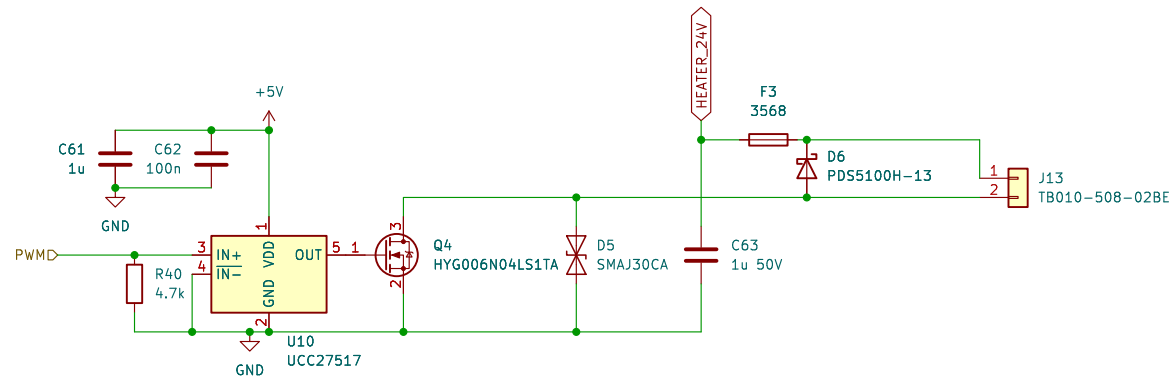

Sheet: /Heater_2/
 File: heater.kicad_sch

Title:

Size: A4
 KiCad E.D.A. 8.0.6

Date:

Rev:

Id: 8/14

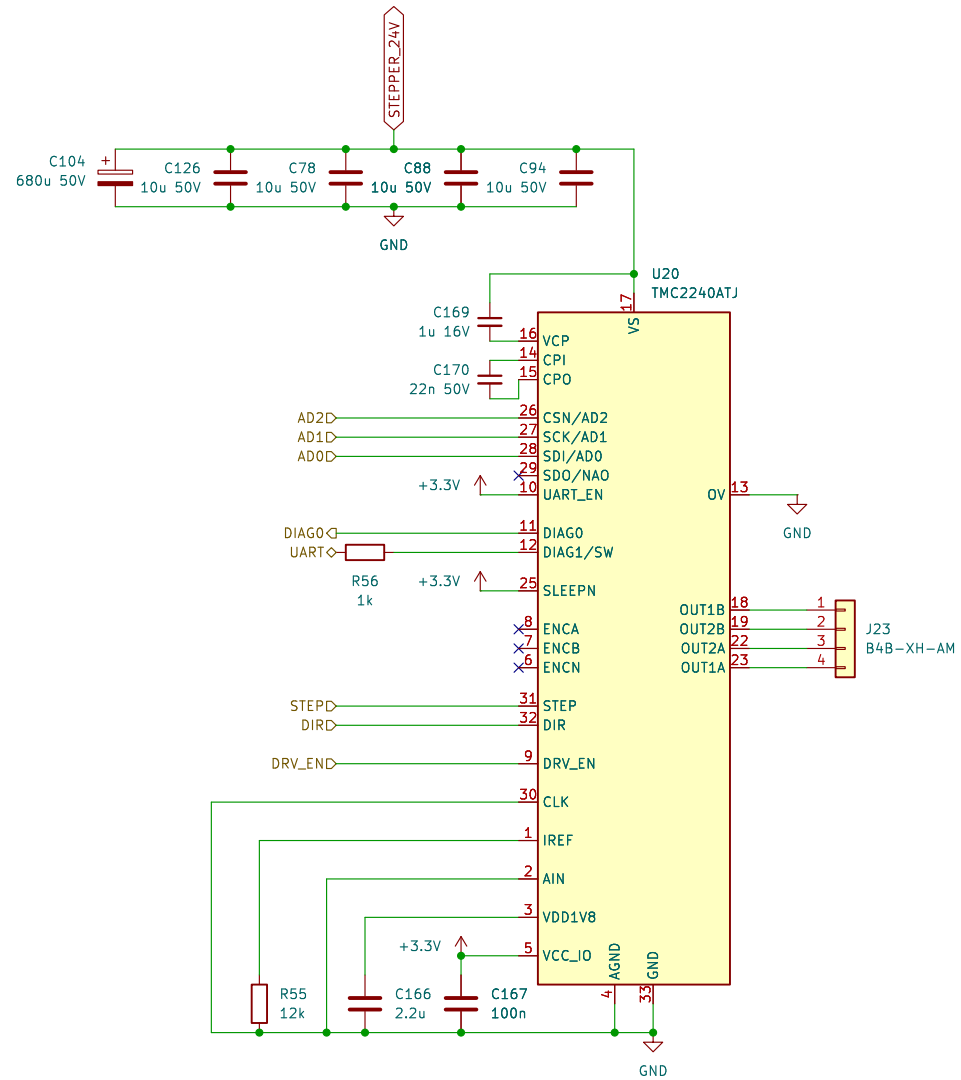

Sheet: /Stepper_1/
 File: stepper.kicad_sch

Title:

Size: A4
 KiCad E.D.A. 8.0.6

Date:

Rev:
 Id: 9/14

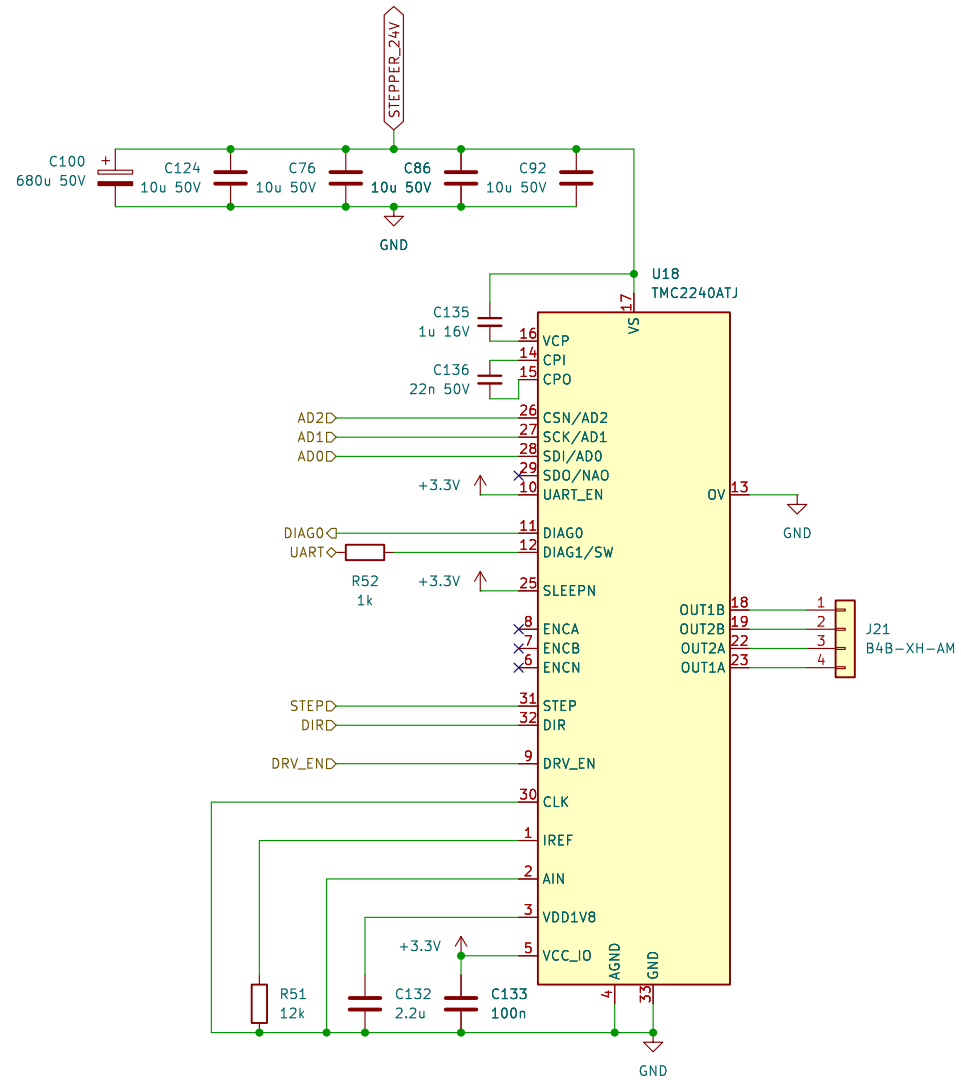

Sheet: /Stepper_2/
 File: stepper.kicad_sch

Title:

Size: A4
 KiCad E.D.A. 8.0.6

Date:

Rev:

Id: 10/14

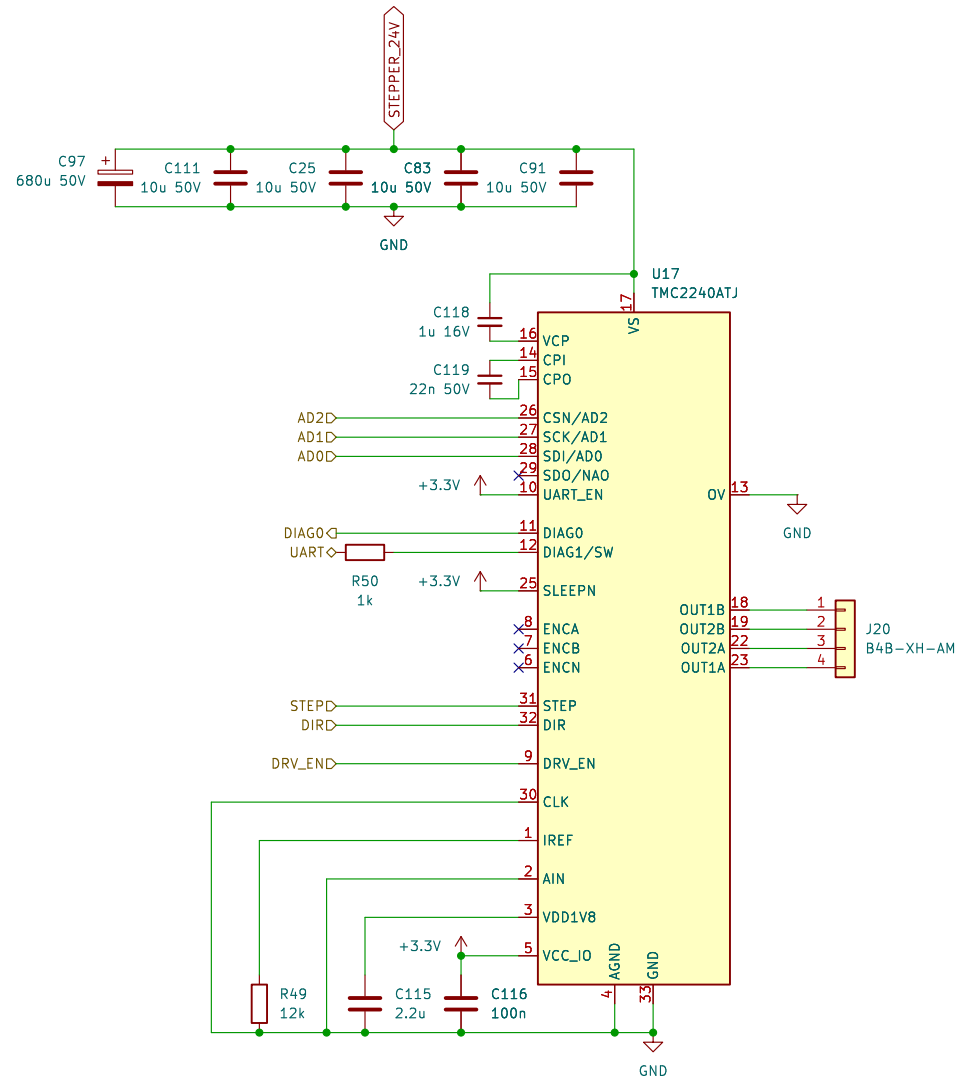

Sheet: /Stepper_3/
 File: stepper.kicad_sch

Title:

Size: A4
 KiCad E.D.A. 8.0.6

Date:

Rev:

Id: 11/14

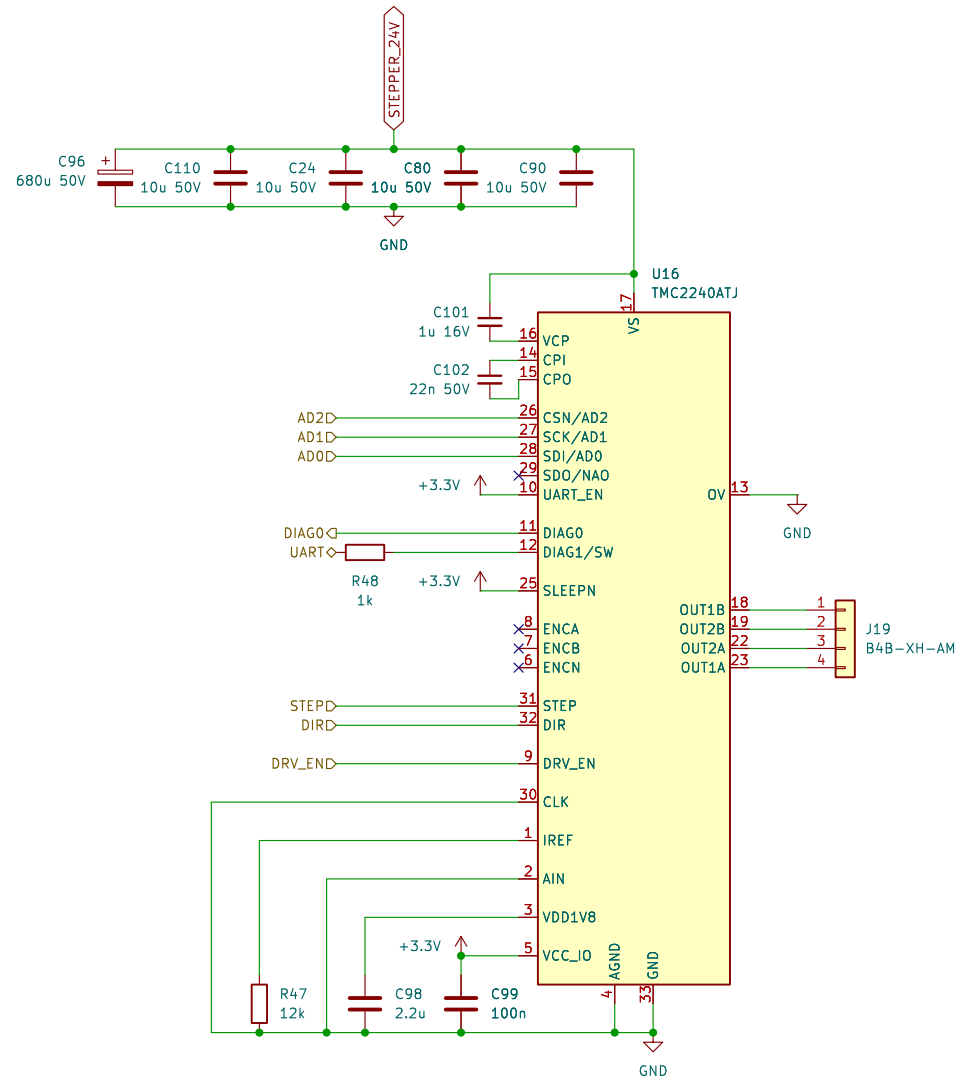

Sheet: /Stepper_4/
 File: stepper.kicad_sch

Title:

Size: A4
 KiCad E.D.A. 8.0.6

Date:

Rev:

Id: 12/14

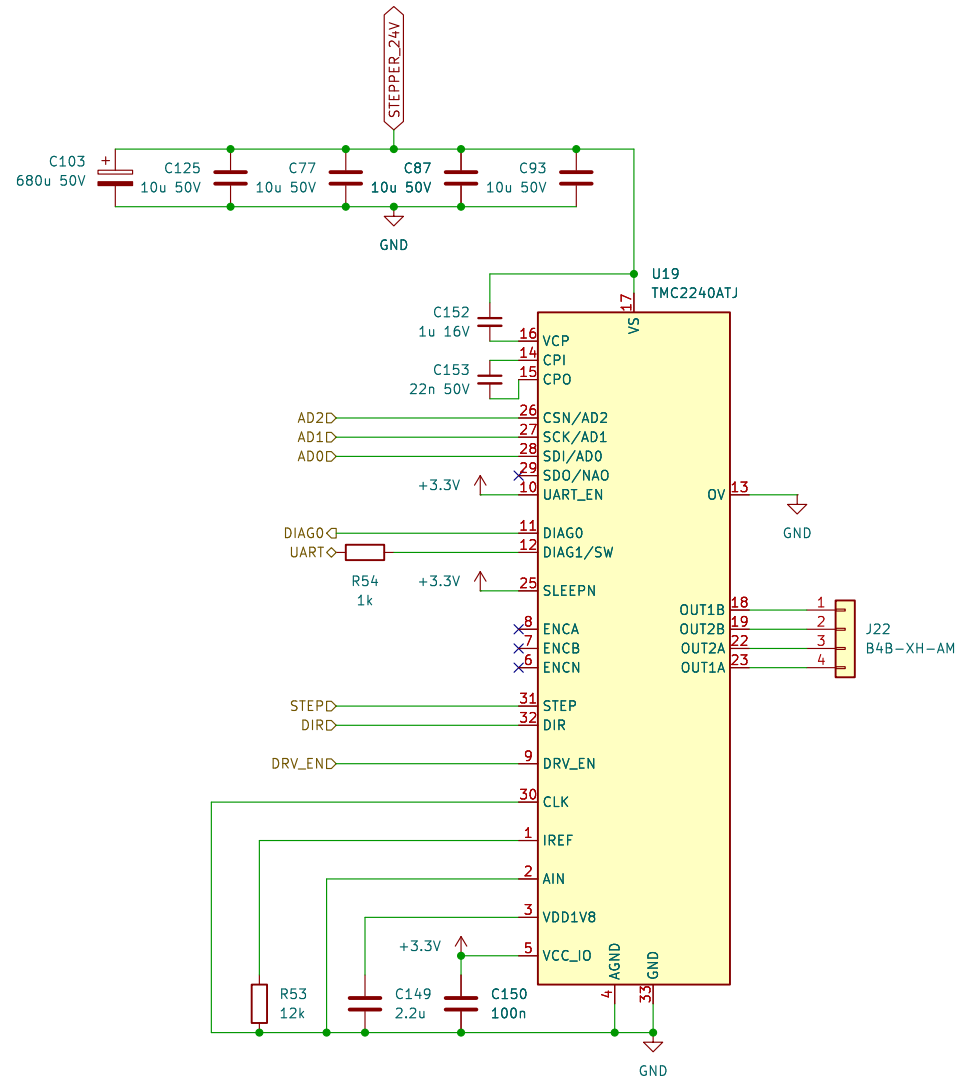

Sheet: /Stepper_5/
File: stepper.kicad_sch

Title:

Size: A4
KiCad E.D.A. 8.0.6

Date:

Rev:
Id: 13/14

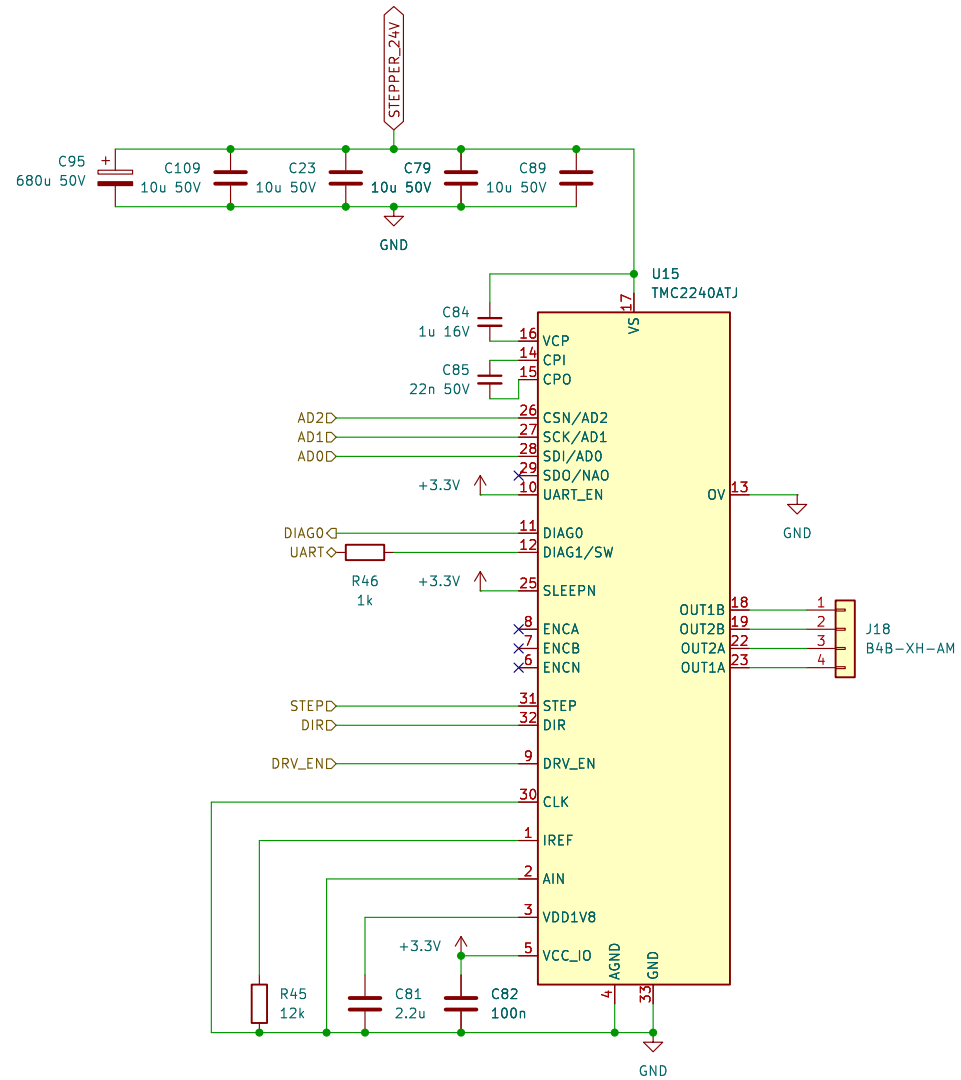

Sheet: /Stepper_6/
 File: stepper.kicad_sch

Title:

Size: A4
 KiCad E.D.A. 8.0.6

Date:

Rev:

Id: 14/14